



Guardex™ M & I Style Couplings



GUARDEX™ COUPLING FEATURES & ADVANTAGES

Double Crowned Tooth Gear Coupling

Double crowned tooth design provides free axial movement, low friction and minimum stress during misalignment. Designs are available with up to 3/8" axial travel.

Nylon Sleeves, Steel Hubs

Molded nylon sleeve with high torsional stiffness, free from any internal frictional losses or heat build-up. A torsionally stiff coupling with minimum backlash.

Nylon and steel components allow high ambient temperature operation without lubrication or maintenance. Continuous operating ambients in the ranges between (-) 13°F and (+) 180°F. Heat stabilized polyamide available for temperatures up to (+) 250°F.

Nylon sleeves resistant to dirt, moisture, most chemicals and petroleum products. No lubrication, seals or retainers to maintain. Easy clean-up and visual inspection.

Compact and lightweight design with high torque and low inertia. Minimum shaft gap for close-coupled applications.

Precision molded concentric sleeve and hubs for high speed applications. No bolts, pins, flanges or protrusions to affect balance or safety. Smooth exterior surface.

Blind Assembly

Suitable for assembly in both horizontal and vertical positions. Blind assembly with slip-together components for easy inspection and adjustment without disassembly.

Metric, Standard, Splined bores available.

Directly Interchangeable With BoWex® Couplings

Made in U.S.A.

GUARDEX™ M-STYLE

- Nylon Sleeve
- Steel Hubs
- Three-Piece Construction

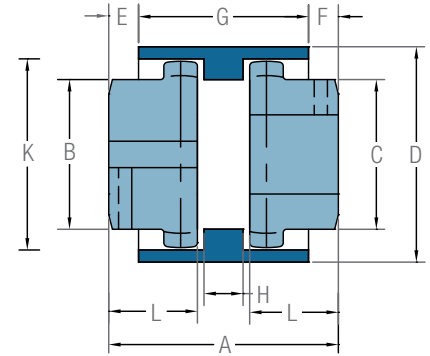

COUPLING SELECTION

| Guardex Coupling No. | Nominal Torque Inch Lbs. | Max. Torque Inch Lbs. | Nominal H.P. @ 1750 RPM | Nominal H.P. @ 1140 RPM | Max. RPM |
|----------------------|--------------------------|-----------------------|-------------------------|-------------------------|----------|
| M-14 | 86 | 265 | 2.5 | 1.5 | 14,000 |
| M-19 | 138 | 425 | 3.7 | 2.5 | 11,800 |
| M-24 | 173 | 531 | 4.5 | 3.2 | 10,600 |
| M-28 | 390 | 1,195 | 10.5 | 7.0 | 8,500 |
| M-32 | 520 | 1,593 | 14.5 | 9.5 | 7,500 |
| M-38 | 694 | 2,124 | 22.0 | 12.5 | 6,700 |
| M-42 | 868 | 2,655 | 24.0 | 16.0 | 6,000 |
| M-48 | 1,215 | 3,717 | 30.0 | 22.0 | 5,600 |
| M-65 | 3,298 | 10,089 | 90.0 | 60.0 | 4,000 |
| M-80 | 6,000 | 18,585 | 165.0 | 110.0 | 3,150 |
| M-100 | 10,600 | 31,860 | 294.0 | 191.0 | 3,000 |

1. Nominal torque ratings allow for 180°F ambient, full misalignment and/or maximum RPM.
2. Starting torque and braking loads should not exceed listed maximum torque.
3. Intermittent, transient peak loads should not exceed three times nominal torque.
4. Applications with uniform loading, well-aligned shafts, and low speeds will allow for operation at maximum torque levels.

INCHES

| Bore Range | Keyway |
|--------------------|---------------|
| 3/8" to 7/16" | 3/32" x 3/64" |
| 1/2" to 9/16" | 1/8" x 1/16" |
| 5/8" to 7/8" | 3/16" x 3/32" |
| 15/16" to 1-1/4" | 1/4" x 1/8" |
| 1-5/16" to 1-3/8" | 5/16" x 5/32" |
| 1-7/16" to 1-3/4" | 3/8" x 3/16" |
| 1-13/16" to 2-1/4" | 1/2" x 1/4" |
| 2-5/16" to 2-3/4" | 5/8" x 5/16" |
| 2-13/16" to 3-1/4" | 3/4" x 3/8" |
| 3-5/16" to 3-3/4" | 7/8" x 7/16" |
| 3-13/16" to 4-1/2" | 1" x 1/2" |

Note: Additional bores and keyways in both inches and millimeters are available. Please inquire.

MILLIMETERS

| Bore Range | Keyway |
|---------------|--------|
| 6-7-8 mm | 2 mm |
| 9-10 mm | 3 mm |
| 11-12 mm | 4 mm |
| 13 thru 17 mm | 5 mm |
| 18 thru 22 mm | 6 mm |
| 23 thru 30 mm | 8 mm |
| 31 thru 38 mm | 10 mm |
| 39 thru 44 mm | 12 mm |
| 45 thru 50 mm | 14 mm |
| 51 thru 58 mm | 16 mm |
| 59 thru 65 mm | 18 mm |
| 66 thru 75 mm | 20 mm |
| 76 thru 85 mm | 22 mm |
| 86 thru 95 mm | 25 mm |

DIMENSIONS

| Type | A | D | B & C | E & F | K | L | G | H | No. of Teeth | Setscrews | lbs | Min./Max. Bore | Bores w/ Keyway | Bores w/o Keyway |
|-------|-------|-------|-------|-------|-------|-------|-------|-------|--------------|-----------|-----|----------------|--|--------------------------|
| M-14 | 1.77" | 1.57" | 1.00" | 0.14" | 1.30" | 0.78" | 1.45" | 0.19" | 20 | 10-24 | 0.4 | 0.187"/0.625" | 7/16, 1/2, 5/8 | 1/4, 3/8, 7/16, 1/2, 5/8 |
| M-19 | 1.96" | 1.90" | 1.25" | 0.25" | 1.53" | 0.86" | 1.45" | 0.28" | 24 | 1/4-20 | 0.6 | 0.375"/0.750" | 1/2, 5/8, 3/4 | 7/16, 1/2, 5/8, 3/4 |
| M-24 | 2.07" | 2.05" | 1.42" | 0.25" | 1.76" | 0.84" | 1.60" | 0.39" | 28 | 1/4-20 | 0.8 | 0.375"/0.945" | 1/2, 5/8, 3/4, 7/8 | 7/16, 1/2 |
| M-28 | 3.17" | 2.58" | 1.97" | 0.69" | 2.12" | 1.40" | 1.80" | 0.37" | 34 | 1/4-20 | 1.8 | 0.250"/1.125" | 1/2, 5/8, 3/4, 7/8, 1-1/8 | 7/16, 1/2 |
| M-32 | 3.15" | 3.00" | 1.97" | 0.63" | 2.47" | 1.40" | 1.92" | 0.35" | 40 | 5/16-18 | 3.2 | 0.437"/1.26" | 1/2, 5/8, 3/4, 7/8, 1-1/8, 1-1/4 | |
| M-38 | 3.15" | 3.25" | 2.30" | 0.65" | 2.70" | 1.40" | 1.90" | 0.35" | 44 | 5/16-18 | 4.0 | 0.437"/1.50" | 1/2, 5/8, 3/4, 7/8, 1-1/8, 1-3/8, 1-1/2 | |
| M-42 | 3.36" | 3.63" | 2.55" | 0.73" | 3.06" | 1.50" | 1.97" | 0.36" | 50 | 5/16-18 | 4.4 | 0.437"/1.65" | 5/8, 3/4, 7/8, 1-1/8, 1-3/8, 1-1/2, 1-5/8 | |
| M-48 | 3.91" | 3.88" | 2.67" | 1.20" | 3.06" | 1.80" | 1.93" | 0.31" | 50 | 3/8-16 | 5.4 | 0.437"/1.89" | 5/8, 3/4, 7/8, 1-1/8, 1-3/8, 1-1/2, 1-5/8, 1-3/4 | |
| M-65 | 5.51" | 5.58" | 3.80" | 1.38" | 4.33" | 2.76" | 2.83" | 0.48" | 42 | 3/8-16 | 15 | 0.500"/2.56" | 1, 1-1/8, 1-3/8, 1-5/8, 1-7/8, 2-1/8, 2-3/8 | |
| M-80 | 7.32" | 6.89" | 4.88" | 1.83" | 5.70" | 3.54" | 3.66" | N/A | 46 | 3/8-16 | 25 | 0.98"/3.15" | 1-7/8, 2-1/8, 2-3/8, 2-7/8, 3-1/8 | |
| M-100 | 8.98" | 8.26" | 5.98" | 2.48" | 6.93" | 4.33" | 4.02" | N/A | 48 | 1/2-13 | 45 | 1.38"/3.94" | As Requested | |

- Assembly Notes:**
1. Dimension "A" is fully compressed. For best misalignment characteristics, 1/16" gap per hub is recommended.
 2. M-80/M-100 sleeves have internal snap ring provisions.

DOUBLE CROWNED TOOTH

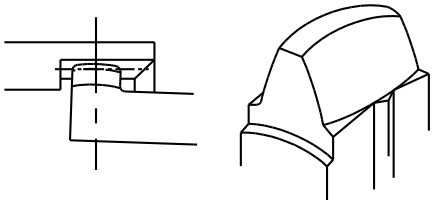

ALIGNMENT TOLERANCES

| Type | Axial Displacement | Angular Misalignment | Parallel Offset | Recommended Hub Spacer Gap |
|-----------------------|--------------------|----------------------|-----------------|----------------------------|
| M-Style (three-piece) | ±.040" | 1°/hub | .016"/hub | .0625"/hub |

- Large contact area to provide low contact pressure and to reduce stress of shaft misalignment.
- Load distributed near the center of the tooth for maximum strength.
- Low friction for a smooth flow of power without the need for lubrication — maintenance free.
- Free axial movement of the coupling parts to compensate for shaft thermal changes and future alignment problems.

Axial Displacement

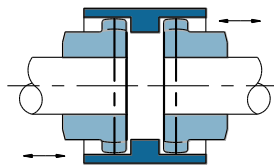

Angular Misalignment

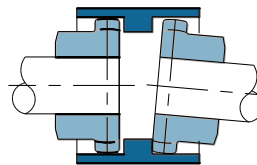

Parallel Offset

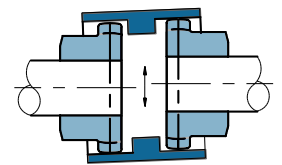

GUARDEX™ I-STYLE

- Coupling has additional axial travel for DEMAG brake motors.
- Sleeve held to one hub with snap rings.
- Opposite hub has free axial travel of up to .500".
- Special hub length available. (See L₁ and L₂)

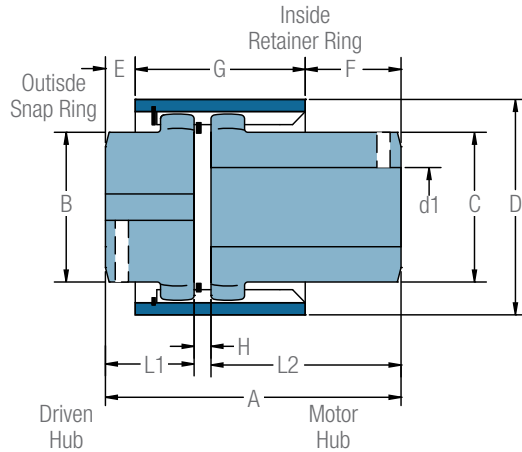

| Guardex Type | Torque Inch Lbs. | | Pilot Bore | Finish Bore | |
|--------------|------------------|--------|----------------|-------------|------------|
| | Nominal | Max. | | Min. | Max. |
| Spec. I-24 | 173 | 531 | 10 mm .393" | 10 .393 | 24 .945 |
| Spec. I-28 | 390 | 1,195 | 7 mm .276" | 7 .276 | 28 1.10 |
| Spec. I-32 | 694 | 1,593 | 12 mm .472" | 12 .472 | 32 1.26 |
| Spec. I-45 | 1,215 | 3,717 | 11 mm .433" | 11 .433 | 45 1.77 |
| Spec. I-65 | 3,298 | 10,089 | 12 mm .472" | 12 .472 | 65 2.56 |

DIMENSION

| DEMAG Size | Guardex Coupling | Axial Travel | Motor Bore d ₁ | A | B & C | D | E | F | G | H | L ₁ | L ₂ |
|--|------------------|----------------|----------------------------|------------------|----------------|-----------------|-----------------|------------------|----------------|---------------|------------------|------------------|
| KBA 71 KBL 71 KBZ 71 | Spec. I-24 | 10 mm .400" | 14 mm .551" | 54 mm 2.13" | 36 mm 1.42" | 58 mm 2.28" | 2.5 mm .098" | 10 mm .393" | 51 mm 2.00" | 4 mm .157" | 21 mm .84" | 30 mm 1.80" |
| KBA 80 KBS 80 | Spec. I-24 | 10 mm .400" | 19 mm .748" | 71 mm 2.80" | 36 mm 1.42" | 58 mm 2.28" | 2.5 mm .098" | 18 mm .700" | 56 mm 2.20" | 4 mm .157" | 21 mm .84" | 46 mm 1.80" |
| KBA 90 KBS 90 | Spec. I-28 | 10 mm .400" | 24 mm .945" | 89 mm 3.52" | 44 mm 1.73" | 70 mm 2.75" | 13 mm .550" | 21 mm .83" | 56 mm 2.20" | 4 mm .157" | 35.5 mm 1.40" | 50.5 mm 2.00" |
| KBA 100 KBS 100 KBA 112 KBS 112 24/10 KS | Spec. I-32 | 10 mm .400" | 28 mm 1.10" | 89 mm 3.49" | 50 mm 1.97" | 84 mm 3.31" | 11 mm .420" | 21 mm .83" | 58 mm 2.28" | 4 mm .157" | 35.5 mm 1.40" | 50.5 mm 2.00" |
| 24/14 KS KBS 125 KBA 125 28/12 KS | Spec. I-45 | 10 mm .400" | 28 mm/1.10" 32 mm/1.26" | 96.5 mm 3.80" | 65 mm 2.56" | 100 mm 3.93" | 14 mm .551" | 23 mm .900" | 60 mm 2.36" | 4 mm .157" | 38 mm 1.50" | 55.5 mm 2.19" |
| 28/17 KS KBS 140 KBA 140 | Spec. I-45 | 10 mm .400" | 28 mm/1.10" 38 mm/1.49" | 96.5 mm 3.80" | 65 mm 2.56" | 100 mm 3.93" | 14 mm .551" | 23 mm .900" | 60 mm 2.36" | 4 mm .157" | 38 mm 1.50" | 55.5 mm 2.19" |
| KBA 160 | Spec. I-65 | 13 mm .500" | 42 mm 1.65" | 138 mm 5.43" | 96 mm 3.78" | 140 mm 5.51" | 30 mm 1.18" | 28.5 mm 1.12" | 84 mm 3.31" | 4 mm .157" | 70 mm 2.76" | 64 mm 2.52" |
| KBA 180 | Spec. I-65 | 13 mm .500" | 48 mm 1.89" | 138 mm 5.43" | 96 mm 3.78" | 140 mm 5.51" | 30 mm 1.18" | 28.5 mm 1.12" | 84 mm 3.31" | 4 mm .157" | 70 mm 2.76" | 64 mm 2.52" |

- Assembly Notes:**
1. Dimensions A, E, & F are measured fully compressed. For best misalignment characteristics, a 1/16" gap per hub is recommended.
 2. Hubs should be mounted flush with the end of the shaft when possible.
 3. Sleeves should move freely in an axial direction after assembly.

Guardian Couplings Facilities

North America

USA

300 Indiana Highway 212
Michigan City, IN 46360
219-874-5248

Engineered Flywheel Couplings, Engine Housings and Pump Mounts, Flexible Shaft Couplings

Europe

United Kingdom

Merchant Drive, Hertford
Hertfordshire SG13 7BL - England
+44(0)1992 501900

Engineered Flywheel Couplings, Engine Housings and Pump Mounts, Flexible Shaft Couplings

The Brands of Altra Motion

Couplings

Ameridrives
www.ameridrives.com

Bibby Turboflex
www.bibbyturboflex.com

Guardian Couplings
www.guardiancouplings.com

Huco
www.huco.com

Lamiflex Couplings
www.lamiflexcouplings.com

Stromag
www.stromag.com

TB Wood's
www.tbwoods.com

Linear Systems

Thomson
www.thomsonlinear.com

Warner Linear
www.warnerlinear.com

Geared Cam Limit Switches

Stromag
www.stromag.com

Engineered Bearing Assemblies

Kilian
www.kilianbearings.com

Electric Clutches & Brakes

Matrix
www.matrix-international.com

Stromag
www.stromag.com

Warner Electric
www.warnerelectric.com

Deltran
www.thomsonlinear.com

Belted Drives

TB Wood's
www.tbwoods.com

Heavy Duty Clutches & Brakes

Twiflex
www.twiflex.com

Stromag
www.stromag.com

Svendborg Brakes
www.svendborg-brakes.com

Wichita Clutch
www.wichitaclutch.com

Gearing & Specialty Components

Bauer Gear Motor
www.bauergears.com

Boston Gear
www.bostongear.com

Delevan
www.delevan.com

Delroyd Worm Gear
www.delroyd.com

Nuttall Gear
www.nuttallgear.com

Engine Braking Systems

Jacobs Vehicle Systems
www.jacobsvehiclesystems.com

Precision Motors & Automation

Kollmorgen
www.kollmorgen.com

Miniature Motors

Portescap
www.portescap.com

Overrunning Clutches

Formsprag Clutch
www.formsprag.com

Marland Clutch
www.marland.com

Stieber
www.stieberclutch.com

Neither the accuracy nor completeness of the information contained in this publication is guaranteed by the company and may be subject to change in its sole discretion. The operating and performance characteristics of these products may vary depending on the application, installation, operating conditions and environmental factors. The company's terms and conditions of sale can be viewed at <http://www.altramotion.com/terms-and-conditions/sales-terms-and-conditions>. These terms and conditions apply to any person who may buy, acquire or use a product referred to herein, including any person who buys from a licensed distributor of these branded products.

©2018 by Guardian Couplings LLC. All rights reserved. All trademarks in this publication are the sole and exclusive property of Guardian Couplings LLC or one of its affiliated companies.